



**- ULTRA SERIES -
PRESSURE FILTER/UV CLARIFIERS**



INSTRUCTION MANUAL



AQUATEC
EQUIPMENT

1300 552 202
www.aquatecequipment.com

PondMAX

- ULTRA SERIES - PRESSURE FILTER/UV CLARIFIERS

	PF4500UV	PF9000UV	PF14000UV
MAXIMUM POND SIZE - WITHOUT FISH - SHADED (L)	4500	9000	14000
MAXIMUM POND SIZE - WITH FISH - FULL SUN (L)	3000	4500	8000
MAXIMUM FLOW (L/H)	3000	4500	8000
VOLTS (V)	240	240	240
ULTRAVIOLET CLARIFIER (W)	11	11	18
FILTER CANISTER SIZE (L)	20	25	35
INLET/OUTLETS Ø (mm)	25 32 40	25 32 40	25 32 40
CABLE LENGTH (m)	5	5	5

DESCRIPTION AND FEATURES

Your PondMax pond filter has been manufactured with advanced technology to provide you with the best quality filter for your pond or waterfeature.

- An Ultra Violet Clarifier incorporated into the filter sterilizes the water giving you crystal clear water.
- A pressure indicator lets you know when the pressure in the filter increases indicating that the filter foams are getting blocked and requires cleaning .
- A large canister and high surface area bio media ensures maximum biological filtration. In normal operation the water enters the filter and is forced around the edge of the filter canister creating a vortex where larger particles are precipitated through gravity. The water then passes through the different density foam sponges, the higher density foam allows the water to pass through slower promoting colonization of Nitrosomonas bacteria and the lower density foam allows the water to pass through faster promoting colonization of Nitrobacter bacteria. The water is then Sterilized by the Ultraviolet light which kills off germs and bacteria and inhibits algae growth and exits the filter back into the pond.
- An integral backwash function back-flushes the filter and compresses the foam sponge media.

INSTALLATION

1. If required, have a qualified electrician install a weatherproof power point near to the pond or water feature (within the cable length of the filter).
2. Identify a suitable location for your new pressure filter. The pressure filter can be used in between a pump and a water feature or waterfall. The filter can also be partially buried to help disguise it in your garden. It is important to return the clean filtered water from your filter to the opposite end of your pond to where the pump suction is located.
3. Connect anti-kink hose or poly tubing from your pump to the inlet of the filter. Your filter has a three step hose tail to suit 25, 32 and 40mm diameter hose or tube. Ensure to cut off the hose tails that are smaller than the hose or tube size being used. Eg: If using 40mm hose, cut off the 25 and 32mm sections. Please use the largest size tubing possible. We recommend using PondMax hose clamps for a leak free connection.
4. Connect tubing from the outlet of the filter back into your pond at the opposite end to where you are pumping from. You can have the outlet of the filter running into a waterfall. You only need to connect tubing to the back-flush outlet if you require the dirty water from the backwash to be diverted to a specific location.
5. If the flow from your pump is greater than the recommended max flow, you must reduce the flow, or bypass some of the flow with a Y piece. The pressure must not exceed 4 meter head.

6. Turn your pump on and then plug in the UV-C unit on the filter. The UV-C unit should not be turned on if there is no water flowing past the UV-C globe.
7. You can help boost the biological function of your filter with PondMax Bacteria. Now sit back, relax and enjoy a clean and healthy pond.

MAINTENANCE

Disconnect power cord from the power supply before performing maintenance. Never lift the filter by the power cord.

The UV-C globe must be checked regularly and should be replaced every 12 months.

To visually check the globe, look through the clear UV-C indicator on the top of the filter and if the light is working you will see a purple glow.

The power cord cannot be replaced. If the cord is damaged, the filter must be discarded.

The filter must be operational 24 hours every day for it to function effectively.

USING THE BACKWASH

1. Whilst the filter is still functioning, connect tubing to the backwash outlet of the filter. You can divert the dirty water into a garden bed or into your drain. Turn the valve on the backwash outlet to open.
2. Now turn the backwash arrow shaped dial on the top of the filter to "clean" mode (the arrow will face towards the ball valve backwash outlet). The water from the normal outlet will now come out the backwash outlet.
3. Turn the cleaning handle anti-clockwise on the filter several times or until the water exiting the backwash outlet becomes clean. This squeezes the filter sponges and cleans them mechanically.
4. Now turn the backwash function dial on the top of the filter back to "filter" mode and close the valve on the backwash outlet.
5. Your filter has now been rinsed, now sit back and enjoy your watergarden.

FULL DISASSEMBLE AND RINSE

1. Turn off your pump and disconnect the power cord from any electrical source. Undo the threaded inlet and outlets from the filter, unclip the lid clamp and carefully remove the lid.
2. Take care not to lose or damage the O-ring seal. Unscrew the clear locking screw at the bottom of the filter sponge layers (or the black base plate on PF9000UV and PF14000UV models). Undo the screw that holds the rod in place and remove the base plate.

3. Now remove the foam sponge rings from off the centre core and rinse them in dechlorinated water or pond water. Using dechlorinated water ensures the chlorine in normal tap water does not kill the beneficial bacteria living in your filter media. Be sure to thoroughly squeeze the sponges to remove sludge.
4. Remove the high efficiency bio media ring (in PF9000UV and PF14000UV Models only) from the bottom of the filter canister and only remove any excess brown sludge from the biospheres. You should not remove all of this brown matter as this is the beneficial bacteria which is essential in the breakdown of toxic waste from your pond.
5. Now clean out the canister of your filter and any debris from the lid of the filter and reassemble. First reassemble the partially cleaned bio media ring into the canister and then insert lid with the foam rings installed onto the center core. The Foam rings should alternate from Blue to Yellow.
6. Now put the lid back in place, taking care to locate the O-ring on the lid of the filter, firmly push the lid back onto the canister. Fasten the lid clamp in place and reconnect the inlet and outlet.
7. Now plug the pump and filter in, turn on, and sit back and enjoy your watergarden.

REPLACING THE GLOBE

1. Turn off power supply and remove plug from power outlet. Turn off your pump.
2. Undo the 4 screws on the top of the filter holding the UV-C Assembly in place.
3. Carefully lift up the UV-C Assembly out of the filter lid. Take care not to impact the quartz sleeve on anything – it will break.
4. Undo the quartz sleeve locking collar at the top of the quartz sleeve. Take care not to lose the quartz sleeve o ring and collar.
5. Carefully remove the quartz sleeve from the UV-C Assembly and place in a secure position.
6. You can now access the globe to replace it. Pull out the old globe and discard responsibly. Insert a new globe ensuring it is connected securely.
7. Replace the quartz sleeve onto the UV-C Assembly ensuring the o ring and collar is located properly. Replace and tighten the quartz sleeve locking collar.
8. Replace the UV-C Assembly into the top of the filter ensuring it fits securely. Tighten the 4 screws fixing the Assembly into the filter lid.
9. Turn your pump back on and then reconnect power supply and turn on your filter. You have successfully replaced your UV-C globe.

- 1 Globe Holder and Ballast
- 2 Globe Holder O Ring and Collar Set
- 3 UV-C Globe
- 4 Globe Cushion
- 5 Quartz Sleeve O Rings
- 6 Quartz Sleeve and Locking Collar
- 7 Backwash Rinsing Handle
- 8 Pressure Filter Lid
- 9 Hosetail Seal
- 10 Clear Stepped Hosetail – Inlet
- 11 Black Stepped Hosetail – Outlet
- 12 Ball Valve/Stepped Hosetail – Backwash
- 13 Backwash Rinsing Paddles
- 14 Yellow Fine Biosponge
- 15 Blue Coarse Biosponge
- 16 Bottom Sponge Plate and Locking Nut
- 17 Bio Media Ring (not included with PF4500UV)
- 18 Lid Clamp
- 19 Lid O Ring
- 20 Filter Canister
- 21 Clamp Locking Key

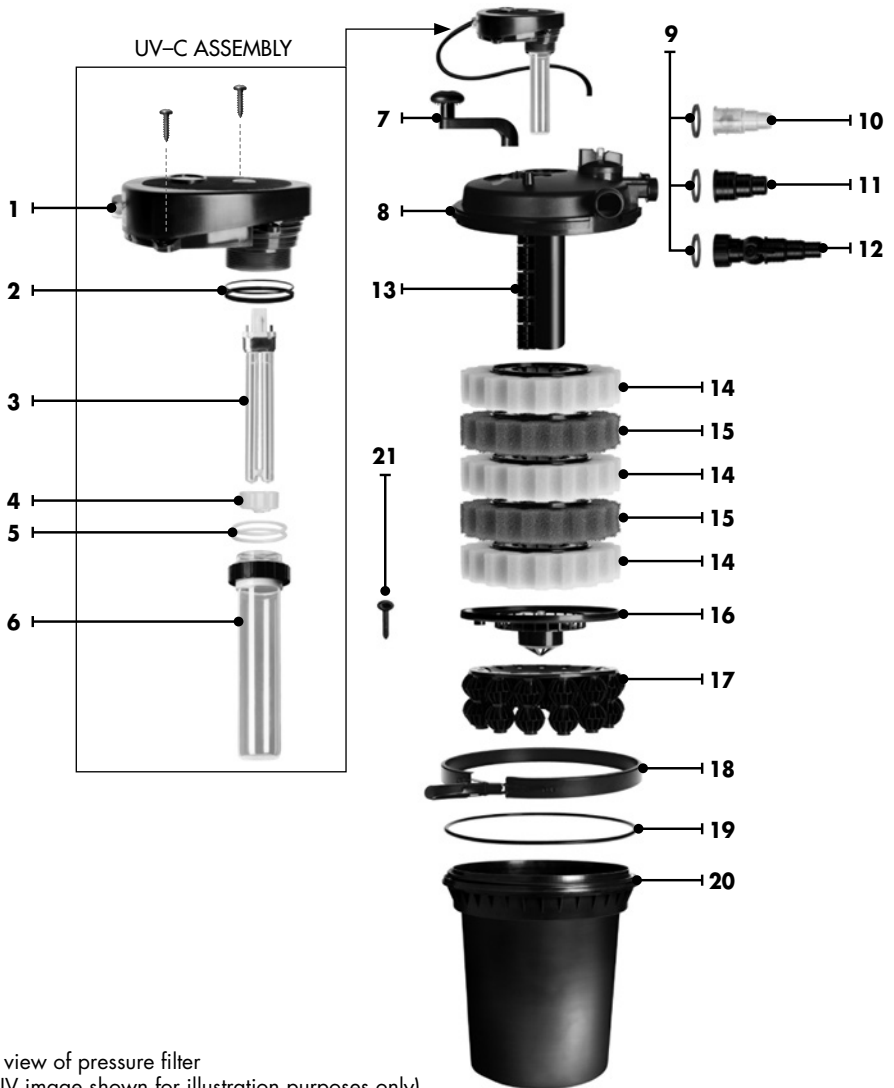

Exploded view of pressure filter
(PF9000UV image shown for illustration purposes only)

IMPORTANT SAFEGUARDS

To guard against injury, basic safety precautions should be observed including, but not limited to the following;

- Do not look at an unshielded UVC globe. Ultra Violet light is harmful to your eyes and may cause blindness.
- Always use a properly grounded power supply that is connected to an RCD with a rated residual operating current not exceeding 30mA. As per AS/NZS 3350.2.41:1997.
- Always unplug the filter from the power supply when not in use or before performing any maintenance on the pump.
- Never pull the cord to disconnect the plug from the power supply. Grasp the plug and pull to disconnect.
- Do not install or store the filter where it will be exposed to extreme hot or cold temperatures.
- Keep out of reach of children or pets. This appliance should not be used by children or infirm persons without supervision.
- Do not cut the cord as this will result in voiding your warranty.
- Care should be taken to arrange the power cord so that it cannot be accidentally tripped over or pulled.
- Do not attempt to repair the filter yourself. Return to an authorized service centre or place of purchase if a fault occurs (regular maintenance is not considered repair and is required by user).

LIMITED WARRANTY

This product comes with a warranty against defects (Warranty). The benefits provided in this Warranty are in addition to other rights and remedies available to you under the Australian Consumer Law. The Warranty is provided to the original purchaser of the product on the following terms:

- The Warranty is given by Chemkay Pty Ltd trading as Aquatec Equipment: Po Box 2087, Seville Grove, WA 6112; contactable by phone (1300 552 202) or email (info@aquatecequipment.com).
- To make a claim under the Warranty you must return the faulty product to the place of purchase with a valid receipt or proof of purchase.
- A Warranty claim must be made within 2 years of the date of purchase.
- If your claim complies with the above terms and the product is not an Exhaustable Item and no Voiding Events have occurred, we will (at our sole discretion):
 - repair the product, if possible; or
 - provide a replacement product; or
 - if a replacement product is not available, provide a refund for the purchase price paid.

- You will bear the cost associated with claiming under the Warranty such as the cost of transportation and delivery of the product to and from the place of purchase.
- The product contains a UVC globe, bio sponges and O rings. These items are exhaustable (Exhaustable Items) and are not covered under the Warranty.
- The Warranty will be void if any of the following events occur, as determined by us, at our sole discretion (Voiding Events):
 - any tampering/removal of warranty/identification labels or electrical components is evident;
 - the defect has arisen due to: an accident, incorrect or inadequate installation, misuse or abuse of the product (including improper maintenance and service), excessive wear and tear, not following manufacturer's guidelines/instructions, or the product has been used in a manner contrary to the purpose or suitability of the product;
 - the product has been modified without our authority;
 - the defect is caused by power surges/spikes/brownouts.
- Loss of livestock, damage to property or personal injury caused by the improper use or abuse of the product will not be covered and the manufacturer excludes all liability for such events, to the extent permitted by law.
- In addition to the Warranty set out above, our goods come with guarantees that cannot be excluded under the Australian Consumer Law. You are entitled to a replacement or refund for a major failure and for compensation for any other reasonably foreseeable loss or damage. You are also entitled to have the goods repaired or replaced if the goods fail to be of acceptable quality and the failure does not amount to a major failure.

E.&O.E.

PondMAX



AQUATEC
EQUIPMENT

1300 552 202
www.aquatecequipment.com